

AUTOMATED SOLUTIONS



Assembly | Inspection | Material Handling



alpha

A TOOLING TECH GROUP COMPANY

The Quality You Need. On Time, Every Time.



AGILE AUTOMATION TO STREAMLINE YOUR MANUFACTURING

Alpha Integration, part of the Tooling Tech Group of companies, designs and manufactures customized solutions for automated assembly, inspection and material handling.

Collaboration is the key to solution success. We begin by gaining an understanding of what you need to achieve in terms of quality and cycle

time. From there, our team of engineers then develops a manufacturing solution to best meet your particular requirements. These solutions may incorporate any number of technologies to complete the required processes. Our solutions range from simple manually operated units to complex, fully automated assembly lines.

Capabilities

We are a complete turnkey solution provider with full in-house capabilities including electrical, mechanical, and software design and engineering, as well as machining, assembly, and service.



Alpha Integration at a Glance

- 72,000 sq. ft. State-of-the-Art Facility
- Design & Engineering
- Controls
- Machining
- Installation & Service
- ABB Certified Partner
- Fanuc Certified Integrator
- Cognex Certified Integrator
- Kuka Certified Integrator
- Yaskawa Certified Integrator

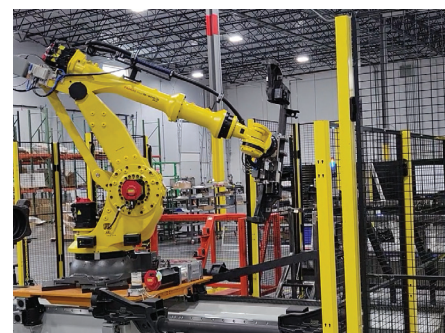

AUTOMATED ASSEMBLY: Streamline Production and Increase Efficiency

- Synchronous/Asynchronous Processes
- High-Speed Assembly
- Small Parts Assembly
- Multiple Product Capability
- Manual Work Cells
- Assembly Mistake-Proof Cells (Poka-Yoke)
- Full Assembly Lines
- Robotic Work Cells
- Volumetric Dispensing
- Weight Dispensing
- Coordinated Motion Bead Path Dispensing
- Volumetric Dispensing
- Bonding Systems
- Drilling Systems
- Screwdriving & Bulk Feeding
- Press with Preload and Rotary Compensation
- Press to Force and/or Distance
- Nut Runners
- Heat Staking
- Adhesive (glue, Loctite, grease)
- Laser Welding
- Ultrasonic Welding
- MIG Welding
- Spot Welding

AUTOMATED INSPECTION: Ensure Quality Control and Identify Defects

- Machine Vision Inspection
- Pressure Decay Leak Test
- Flow Test
- Electrical Properties
- Dimensional Gauging (Vision/Laser/Physical)
- High-Pressure Proof Testing
- Laser, Inkjet, Impact Marking
- Barcode
- 2D Matrix
- RFID Systems
- Labeling
- Traceability
- Incoming Material Lot Control
- Assembly Birth Certificates
- Statistical Process Control Data Collection/Monitoring
- Traceability

MATERIAL HANDLING: Improve Productivity, Efficiency and Safety

- Robotic/Servo Control Integration
- Gantry Systems
- Conveyor Systems
- AGV's
- Rotary Dial Indexers
- Walking Beam Indexers
- Large Bulk Container Management
- Vibratory Feeding
- Labelling
- Barcoding
- RFID Systems

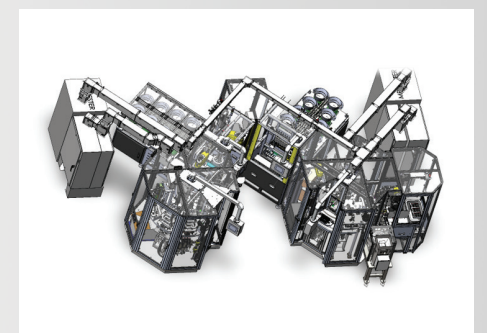
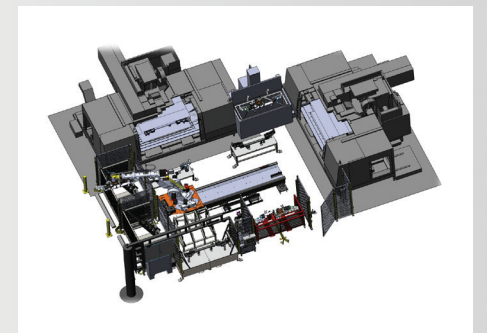



COMPANY OVERVIEW

Alpha Integration, founded in 2001, specializes in the development and manufacture of solutions for automating assembly processes including material handling, dispensing, sorting, testing, welding, fastening and more for the automotive, cosmetic, electrical, construction and life sciences industries. Alpha was purchased in 2019 by Tooling Tech Group, founded in 1982.

Tooling Tech Group builds custom automated systems for assembly, joining and inspection as well as tooling for a variety of applications including thermoform molding, high compression composite molding, blow molding, rotational molding, die casting, and stamping. Industries served include automotive, appliance, lawn and garden, agricultural, aerospace, marine, and off-road vehicle industries, among others. Through organic growth and acquisitions, the company has become the largest tooling provider in the United States with 650+ employees, 13 modern facilities and over 1 million square feet of manufacturing space across four states.

The depth and breadth of our capabilities is achieved through the combined experience of our company units, with each of these companies being in business for 30+ years, providing both extensive industry experience and financial stability that you can rely upon. Our unique differentiator is the ability to provide all tooling services from design to engineering to simulation to machining to fabrication to try-out all within one company. This single source ability can help to streamline your business operations and simplify your life. We take full responsibility for quality, delivery, and cost management of each project starting at concept through “on time, every time” delivery.



TOOLINGTECH GROUP

Tooling Tech Group
Corporate Offices
200 South Alloy Drive
Fenton, Michigan 48430

Tel: +1 (231) 400-4884

TTG Alpha
Main Office
249 Mason Road
La Vergne, Tennessee 37086

Tel: +1 (615) 898-6200