

MINI CYLINDER LOCK - FLANGE MOUNT INSTALLATION INFORMATION

FOR CAT.# PD375F

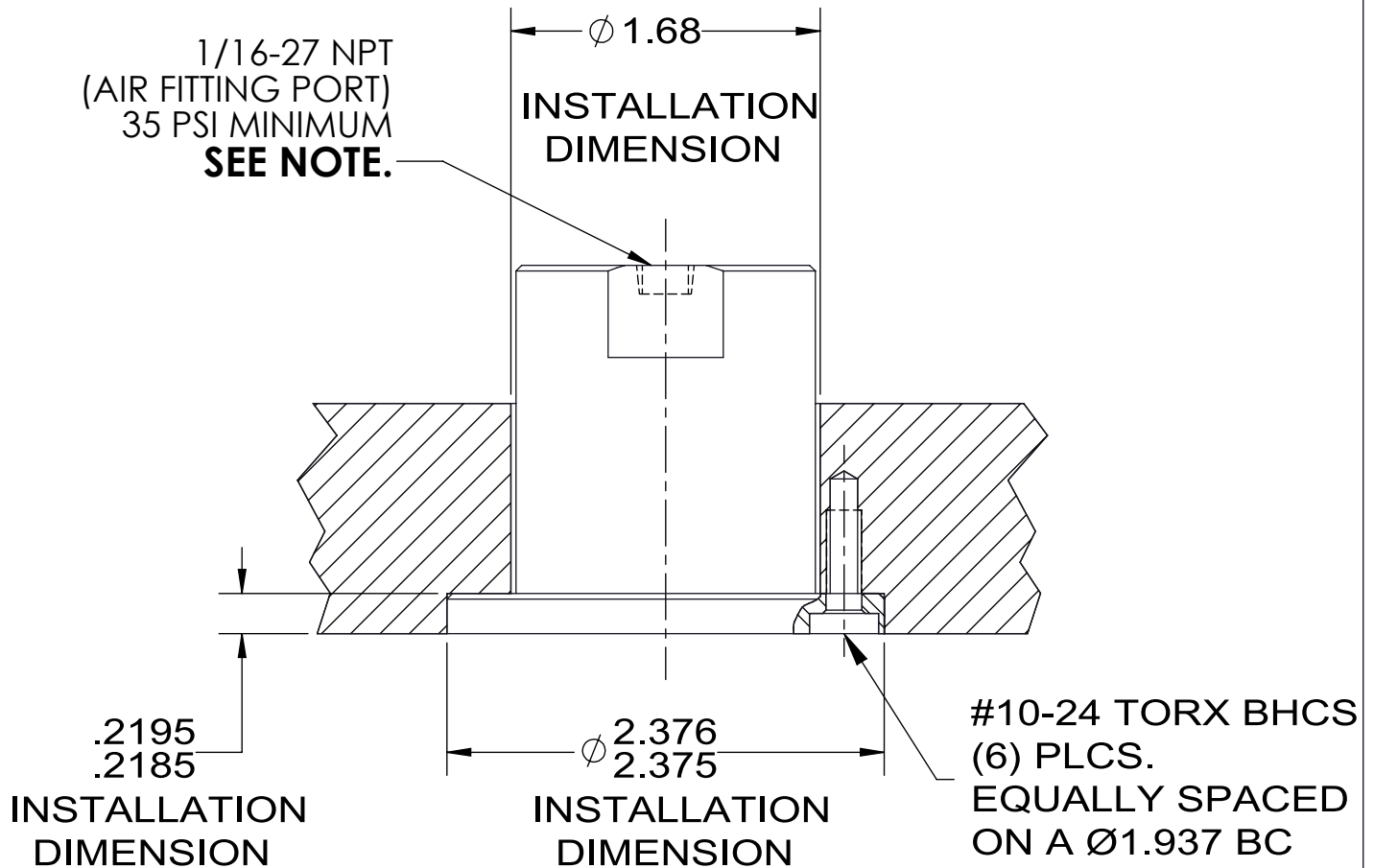

NOTE: WHEN INSTALLING 1/16-27 AIR FITTING DO NOT EXCEED TWO FULL REVOLUTIONS. EXCESSIVE FITTING ENGAGEMENT CAN INTERFERE WITH THE CYLINDER LOCKS ABILITY TO ACTUATE PROPERLY, CAUSING IT TO MALFUNCTION!

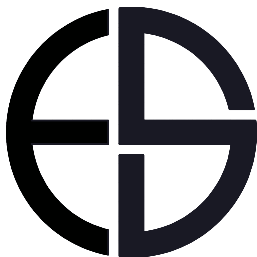

EDWARD D. SEGEN & CO, LLC

100 Enterprise Drive, Ft. Loramie, OH 45845

PH.937.295.2281 FAX 937.295.3677

www.toolingtechgroup.com

THE INFORMATION CONTAINED HEREIN MAY BE THE SUBJECT OF PENDING OR CONTEMPLATED PATENTS, AND IS FURNISHED WITHOUT PREJUDICE TO THE PATENT RIGHTS OF EDWARD D. SEGEN & CO, LLC.